

COMPRESSED AIR MODULES FOR ROAD AND RAIL

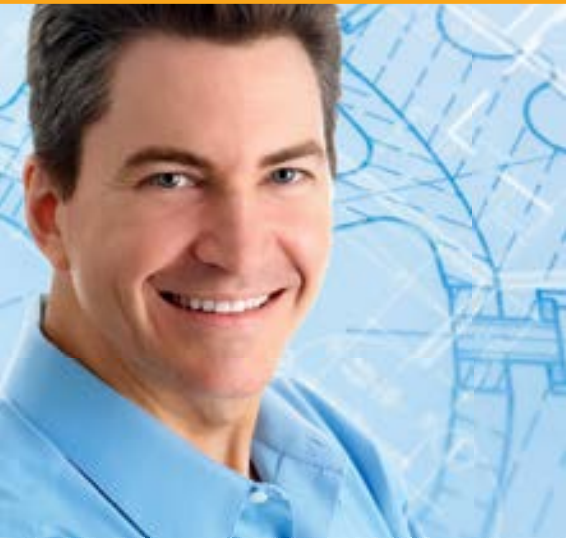

TRACKAIR

A graphic element consisting of several white horizontal lines of varying lengths, stacked vertically, resembling a stylized train or a set of tracks.

INTELLIGENT COMPRESSED AIR ...

These certificates guarantee safety and reliability

Our modules conform to the state-of-the-art in research and technology and, of course, they are manufactured in line with

- IRIS 02
- ISO 9001:2008
- ISO 14001:2004

The ALMiG company is certified in compliance with the International Railway Industry Standard (IRIS: Reg.-No1211320642).

All plants meet the acceptance requirements according to

- ISO 1217-3 Annex C-1996
- ASME
- OSHA

and are in compliance with the CE guidelines.

Acceptance in compliance with:

- DET NORSKE VERITAS
- GERMANISCHER LLOYD
- BUREAU VERITAS
- LLOYD' s REGISTER OF SHIPPING
- ABS

is a matter of course for us.

Conclusion:

You're always on the safe side with us!

You are on the right track with them!

customised systems

Tell us your requirements and our engineers will provide you with the perfect solution

flexible modular system

From a plenitude of potential configurations and drive systems, we will work out the "right product" together with you

small dimensions and low weights

There is hardly an "installation space" too small for us; we regard it as a matter of course to reduce the weight with the help of a variety of materials

easy to maintain

The basis for this is good accessibility and the careful selection of components

highest safety standard

What we are offering you and your customer is above-average reliability



... MADE IN GERMANY



A CLEVER MODULAR SYSTEM ...

Which options do you wish to have?

To be able to react even better and more flexibly to the requirements of the wide variety of applications, we provide you with a very broad range of options. This rounds off the ALMiG modular system even better. Some examples that stand for this:

- steel or aluminium frames
 - underfloor or roof mounting
 - integrated compressed air treatment
 - integrated or higher order control
 - dryer
 - condensate collectors
 - test frame
 - with or without covering
 - heating
 - integrated fire alarm
- ... or simply explain what you wish to have!



The test frames for the modules facilitate reliable preparation for installation and a test run following inspection. It could hardly be more simple, time-saving and reliable.



... FOR ALMOST EVERY USE

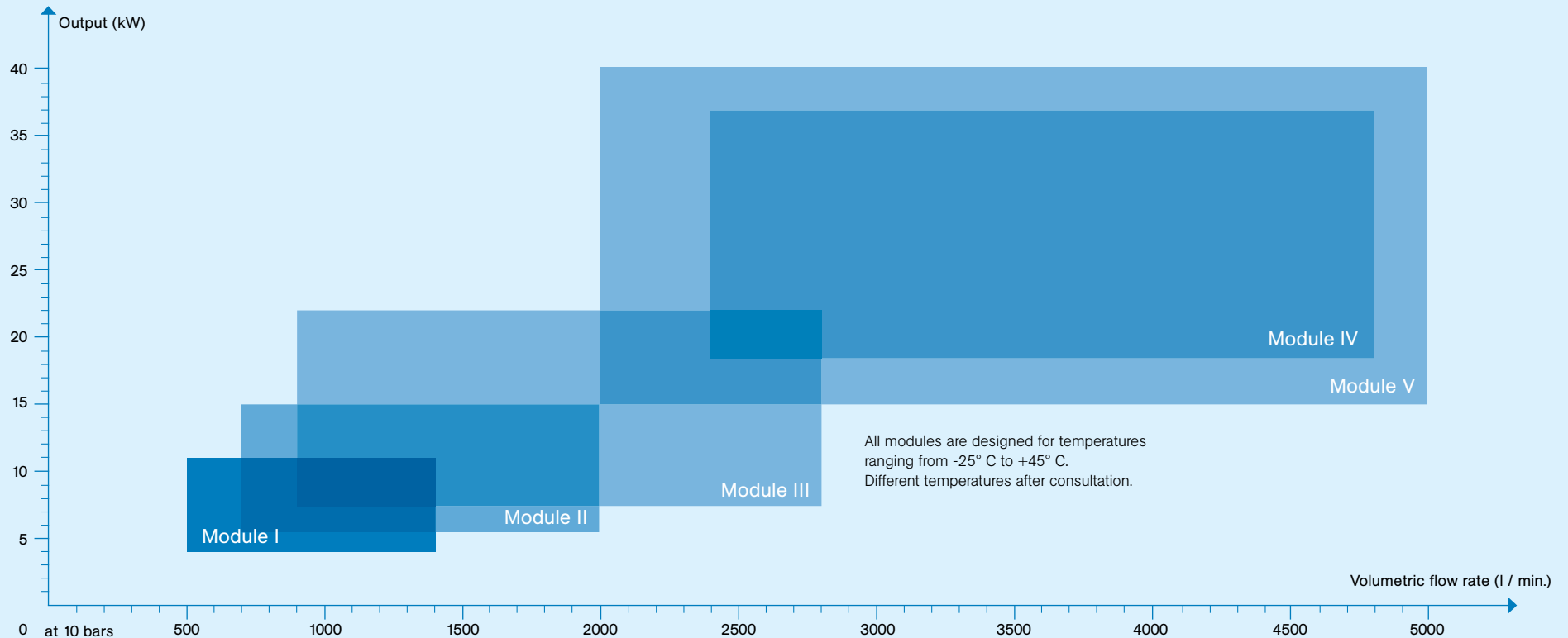

Type	Types of drive					
	Direct	Gear	Speed-controlled	Hydro drive	Drive shaft	V belt
Module I	✓	—	✓	✓	✓	✓
Module II	✓	—	✓	✓	✓	✓
Module III	✓	✓	✓	✓	✓	✓
Module IV	✓	—	✓	✓	✓	✓
Module V	✓	✓	✓	✓	✓	✓

Types of drives:

It is not without reason that ALMiG offers a great number of different types of drives. Geared to your specific application, we are in a position to configure almost all of the available compressor modules, irrespective of the type of drive.

OUR MODULES PROVE THEIR WORTH EVERY SINGLE DAY IN OPERATION ...

... and are extremely simple to service.

1

Picture 1 shows a TRACKAIR compressor module mounted underfloor with an integrated adsorption dryer for clean, dry compressed air.

The AirControl compressor control unit, also integrated, facilitates convenient and simple monitoring of maintenance cycles and furthermore guarantees high availability thanks to the best possible monitoring of all components.

A fire alarm has also been integrated to guarantee maximum safety in passenger operation. Thanks to generously dimensioned cooling and electrical components the modules are suitable for combined tunnel and outdoor operation under fast-changing ambient conditions.

2

The modules can also be used as a substitute for existing compressors (see picture 2). They are specially adapted for the installation conditions with interfaces that are compatible with the replacement compressors.

In addition to the cartridge technology, the extremely robust, open design guarantees short maintenance times with long intervals in between.

3

To begin with, there is the requirement profile of our customer. In collaboration with our partners' development engineers the idea is transformed into the finished product.

As picture 3 demonstrates by way of example, with this compact compressor module the cooler unit is mounted separately to facilitate perfect adaptation to small spaces.

The module demonstrated is designed for around 3900 l/min. at extreme ambient temperatures up to + 58° C.

4

When the modules were designed, special attention was paid to the accessibility of the components.

This guarantees easy, cost-cutting maintenance. The consistent use of cartridges also facilitates fast maintenance and hence short stoppages.

Your maintenance personnel do not require special skills for the ALMiG modules.



... NEVER LEAVE ANYTHING TO CHANCE

Test, test and test again!

1

Simulation of snow particle trajectories with the anticipated particle residence time in the underfloor area.

The graphic representations show forward travel (80 km/h) on a free stretch during wind and snowfall from the front by way of example. The quantity of snow introduced is equivalent to a snowfall rate of 30 cm per hour.

2

This picture shows the strength calculation for the frame of a modified screw compressor, i.e. for a "detailed FEM model".

The static load cases were chosen in accordance with DIN 12663 for category III passenger vehicles (underground and suburban railway vehicles).

The calculated result according to the FEM directive means: "This design is sufficiently dimensioned to tolerate calculated test loads".

3

In this shake test the life cycle (total service life) of the TRACKAIR module is simulated.

This test carried out under extreme conditions is shortened to approximately 20h fatigue loading; according to DIN EN 61373 it serves as practical proof of whether the FEM calculation is correct.

4

Our modules are put through their paces in appropriate climate chambers.

The cold test (in this case down to -30 °C) is intended to assist in optimising the starting action of the modules, ensuring the functional safety during drive mode, and selecting the optimal coolant.

We give top priority to operating reliability and functionality with regard to the TRACKAIR modules! ALMiG considers extensive calculations, complex simulations and ample endurance tests under extreme conditions to be a matter of course prior to producing a 0 series.

We perform these calculations/tests on our premises and in collaboration with specialised test laboratories and renowned universities. Only when all those involved give the go-ahead, do our development engineers and production initiate the next steps.

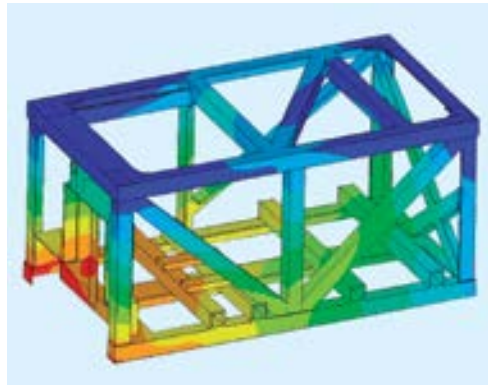
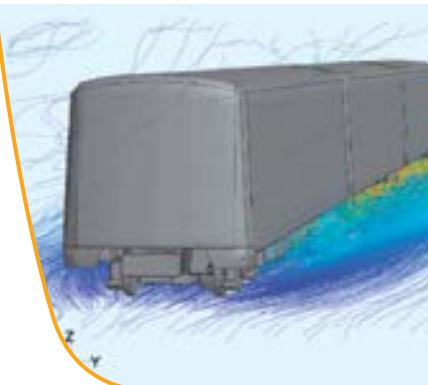

INTELLIGENTE DRUCKLUFT MADE IN GERMANY

In line with the customer's needs

With our innovative system concepts we offer customised solutions for almost all applications. Our endeavour lies not only in supplying compressors, we

offer ourselves as a competent system provider capable of offering solutions to all users of compressed air. That does not only apply to the consultation and installa-

tion phase of your new compressor(s), but naturally continues in all areas of service, maintenance and visualisation.
Challenge us!

Screw compressors 3-500 kW	Piston compressors 1.5-55 kW	Turbo compressors 200-2.000 kW	Blower 1.5-55 kW	Complete accessories	Control, regulate, monitor
<ul style="list-style-type: none"> • Fixed speed • With energy-saving speed control • Oil-free, with water injection • Oil-free, 2-stage <p>Available drive types:</p> <ul style="list-style-type: none"> • V-belt • Gearbox • Direct 	<ul style="list-style-type: none"> • Oil-lubricated • Oil-free • Normal pressure, medium pressure, high pressure • Booster • Mobile/stationary <p>Available drive types:</p> <ul style="list-style-type: none"> • V-belt • Direct 	<ul style="list-style-type: none"> • Oil-free • Radial, 3-stage compression • With/without sound-absorbing housing <p>Available drive types:</p> <ul style="list-style-type: none"> • Gearbox 	<ul style="list-style-type: none"> • Fixed speed • With energy-saving speed control <p>Available drive types:</p> <ul style="list-style-type: none"> • V-belt • Direct 	<ul style="list-style-type: none"> • Refrigerant dryers • Desiccant dryers, heatless and heat-regenerative • HOC (heat of compression) • Activated carbon adsorbers • Filters, all particle sizes • Condensate management • Heat recovery systems • Pipework systems <p>All components are optimally matched to the compressors.</p>	<ul style="list-style-type: none"> • Base load changeover controls • Consumption-related controls • Visualisation (we display your compressed airstation on the PC) • Telemonitoring (the hotline of your compressed air station)

Our quality standards mean you can rely on our machines



ISO 9001



ISO 14001



IRIS



Partner of the Engineering Industry Sustainability Initiative



DNV



Your expert advisor

ALMiG Kompressoren GmbH
Adolf-Ehmann-Straße 2 • 73257 Köngen
Tel. Vertrieb: +49 (0)7024 9614-240
E-Mail Vertrieb: sales@almig.de
www.almig.de